



Features:

- The minor error connects between two shafts can be removed.
- The machining accuracy can be neglected.
- The shaft alignment's time for the error tolerance connects between two shafts can be finished and installed easily, even the newcomer can do also.
- The abnormal noise can be prohibited.
- Small in dimension but can be loaded high tension & compression.
- Long time for the machine parts and the packing in the cylinder or the rod sealing's damage can be prohibited, reduced the producing's cost.
- The compression's decrease can be prohibited.

Order example:

MFC – 1004 T

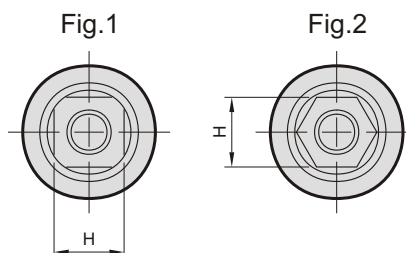
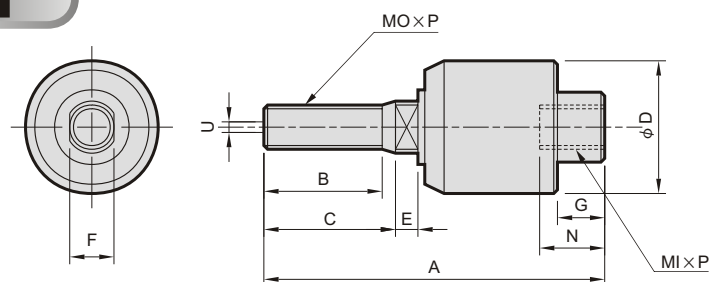
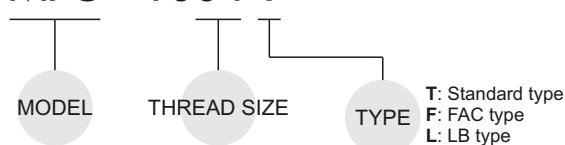

Model	Cyl. dia	MI × P	MO × P	A	B	C	D	E	F	G	H	N	Permissible U deviation	Illustration fig no.	Weight
MFC-1003T	6	M3 × 0.5	M3 × 0.5	24.5	8	9	12	2	3	4	8	7	0.5	Fig.1	10 g
MFC-1004T	8	M4 × 0.7	M4 × 0.7	24.5	8	9	12	2	4	4	8	7	0.5	Fig.1	10 g
MFC-1005T	10, 15	M5 × 0.8	M5 × 0.8	38	14	15	18	3	5	5	11	9	0.5	Fig.1	30 g
MFC-1006T	15	M6 × 1.0	M6 × 1.0	38	14	15	18	3	6	5	11	9	0.5	Fig.1	30 g
MFC-1008T	20	M8 × 1.25	M8 × 1.25	50	18	20	24	4	8	7	14	12	0.5	Fig.1	70 g
MFC-1010T	25, 30	M10 × 1.25/1.5	M10 × 1.25/1.5	59	20	22	26	5	10	7	17	14	0.75	Fig.1	103 g
MFC-1012T	40	M12 × 1.25/1.5/1.75	M12 × 1.25/1.5/1.75	57	20	22	28	5	12	8	19	12	0.75	Fig.1	121 g
MFC-1014T	40	M14 × 1.5	M14 × 1.5	70	21	24	35	7	14	8	22	17	1	Fig.1	245 g
MFC-1016T	50, 63	M16 × 1.5	M16 × 1.5	90	26	28	45	9	16	13	28	24	1.25	Fig.1	500 g
MFC-1018T	50, 63	M18 × 1.5	M18 × 1.5	90	26	28	45	9	18	13	28	24	1.25	Fig.1	500 g
MFC-1020T	80	M20 × 1.5	M20 × 1.5	103	30	32	55	10	20	16	32	27	2	Fig.2	800 g
MFC-1022T	80	M22 × 1.5	M22 × 1.5	103	30	32	55	10	22	16	32	27	2	Fig.2	800 g
MFC-1024T	100	M24 × 1.5	M24 × 1.5	124	35	38	61	12	24	19	41	33	2.5	Fig.2	1.3 kg
MFC-1026T	100	M26 × 1.5	M26 × 1.5	130	43	45	61	12	26	19	41	33	2.5	Fig.2	1.3 kg
MFC-1027T	125	M27 × 2.0	M27 × 2.0	153	63	65	63	20	27	19	41	33	2.5	Fig.2	1.7 kg
MFC-1030T	125, 140	M30 × 1.5/2.0/3.5	M30 × 1.5/2.0/3.5	153	57	59	63	20	30	18	41	33	3	Fig.2	1.7 kg
MFC-1036T	140, 160	M36 × 1.5/2.0	M36 × 1.5/2.0	195	80	82	75	18	36	22	50	41	4	Fig.2	2.9 kg
MFC-1040T	160	M40 × 2.0	M40 × 2.0	194	82	100	75	18	40	23	54	41	5	Fig.2	7.5 kg
MFC-1045T	160	M45 × 2.0	M45 × 2.0	205	78	95	85	14	45	33.5	64	50	5	Fig.2	8.0 kg
MFC-1050T	160	M50 × 2.0	M50 × 2.0	208	78	95	85	14	50	33.5	64	50	6	Fig.2	

※Permissible pressure range: pneumatic pressure must below 10kgf/cm², hydraulic pressure must below 70kgf/cm².

F

Fig.3

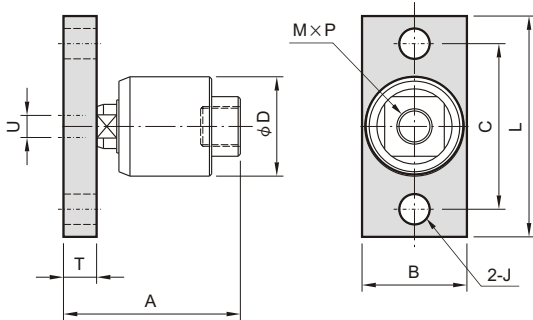
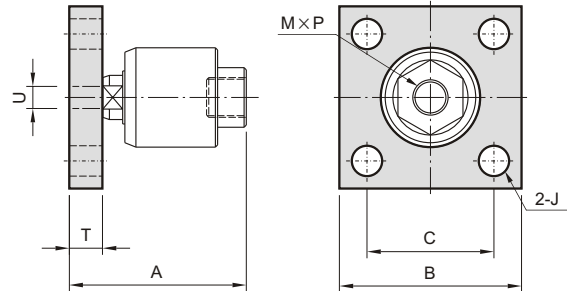

Fig.4



Model	Cyl. dia	M×P	A	B	C	J	L	T	Permissible U deviation	Illustration fig no.	Weight
MFC-1008F	20	M8×1.25	38	25	40	7	52	6	0.5	Fig.3	120 g
MFC-1010F	25, 30	M10×1.25	46	32	44	7	56	9	0.75	Fig.3	210 g
MFC-1012F	40	M12×1.25	46	32	44	7	56	9	0.75	Fig.3	220 g
MFC-1014F	40	M14×1.5	61	38	60	11	80	12	1	Fig.3	500 g
MFC-1018F	50, 63	M18×1.5	80	74	45	11	-	15	1.25	Fig.4	1.1 kg
MFC-1020F	80	M20×1.5	91	100	62	14	-	18	1.25	Fig.4	1.1 kg
MFC-1026F	100	M26×1.5	108	100	70	14	-	21	2.5	Fig.4	2.2 kg
MFC-1027F	125	M27×2.0	111	100	70	14	-	21	2.5	Fig.4	-
MFC-1030F	125, 140	M30×1.5	117	100	70	14	-	21	3	Fig.4	2.7 kg
MFC-1036F	140, 160	M36×1.5	140	130	95	16	-	25	4	Fig.4	2.8 kg

※Permissible pressure range: pneumatic pressure must below 10kgf/cm², hydraulic pressure must below 70kgf/cm².

L

Fig.5

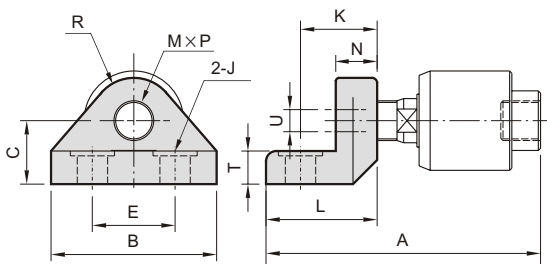
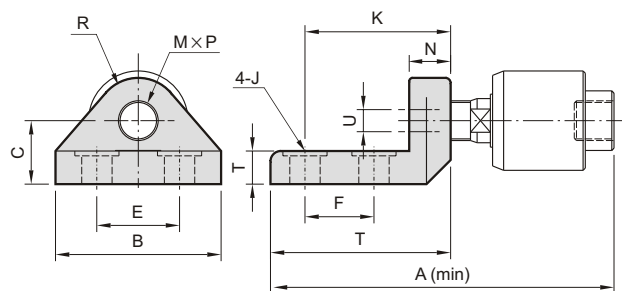

Fig.6



Model	Cyl. dia	M×P	A	B	C	E	F	J	K	L	N	R	T	Illustration fig no.	Weight
MFC-1008L	20	M8×1.25	61	44	15	26	-	9	19	29	11	9	4	Fig.5	149 g
MFC-1010L	25, 30	M10×1.25	72	44	19	26	-	9	24	35	13	10	5	Fig.5	223 g
MFC-1012L	40	M12×1.5	72	44	19	26	-	9	24	35	13	10	5	Fig.5	240 g
MFC-1014L	40	M14×1.5	105	66	22	36	-	11	40.5	56	21	15	10	Fig.5	600 g
MFC-1018L	50, 63	M18×1.5	155	60	28	32	32	11	76	90	31	17	15	Fig.6	1.2 kg
MFC-1022L	80	M22×1.5	179	68	35	36	36	14	89	106	40	19	20	Fig.6	2.0 kg
MFC-1026L	100	M26×1.5	199	68	42	36	36	14	95	112	46	21	20	Fig.6	2.4 kg

※Permissible pressure range: pneumatic pressure must below 10kgf/cm², hydraulic pressure must below 70kgf/cm².